



# XQ 1750 Utility Convertible Rental Package

**Sound Attenuated**

XQ1750-1750 kW

Prime Power including 10% overload

## FEATURES

### ■ CAT® GENERATOR SETS

Factory designed, certified prototype tested with torsional analysis. Production tested and delivered to you in a package that is ready to be connected to your fuel and power lines. Supported 100% by your Caterpillar dealer with warranty on parts and labor; extended warranty available in some areas.

### ■ RELIABLE, FUEL EFFICIENT DIESEL

The compact, four-stroke-cycle diesel engine combines durability with minimum weight while providing dependability and economy. The fuel system operates on a variety of fuels.

### ■ THE CATERPILLAR® GENERATOR

Single bearing, wye connected six lead permanent magnet excited, static regulated, brushless generator designed to match the performance and output characteristics of the Caterpillar diesel engine that drives it.

### ■ EXCLUSIVE CATERPILLAR® VOLTAGE REGULATOR

Three-phase sensing and Volts-per-Hertz regulation with excellent block loading and constant voltage in the normal operating range.

### ■ CATERPILLAR® COOLING SYSTEM

Sized compatible to rating with energy efficient fan and core.

### ■ ISO 9001 QUALITY SYSTEM STANDARD

Generator set designed and manufactured in conformance with ISO 9001 Quality System Standard; and generator set and components meet or exceed the following specifications: AS1359, AS2789, ABGSM TM3, BS4999, DIN6271, DIN6280, EGSA101P, JEM1359, IEC 34/1, ISO3046/1, ISO DIS 8528, NEMA MG1-22, 89/392 EEC.

### ■ CATERPILLAR® SWITCHGEAR

EMCP II based, semiautomatic paralleling components. Circuit breakers, bus bars, and connection panel ready to connect.

### ■ PLUG & PEAK SHAVE UTILITY CONVERSION PANELS (OPTIONAL)

The addition of the conversion panels will allow automatic or manual paralleling with a utility power source as a load management system with provisions for standby operation feeding an isolated load network. Easily installed in a few minutes by two people using four bolts and two quick connect type connectors per panel. Includes utility protective relays, loading controls, utility metering.

### ■ SOUND ATTENUATED, ISO CONTAINER

For ease of transportation and protection. Meets ISO/TC104, ANSI/MH5.1, and UIC Code 592-1. Meets 70 dBA at 50 ft or below per SAE J1074 measurement procedure.



### STANDARD EQUIPMENT

---

#### Engine

Air cleaner with service indicator  
 Batteries  
 Filters  
     fuel LH with service indicators  
     lubricating oil  
 Insulated muffler  
 Jacket water heater  
 Pump, fuel priming  
 Radiator  
 Service meter  
 Standard eight-gauge instrument panel  
 Sump pump

#### Generator

SR4 brushless, 480 volt  
     PM excited  
 Three-phase, with voltage regulator  
     and space heater

#### Container

Side air intake louvers  
 Bus bar access door  
 Fuel tank w/sight gauge  
     40-ft, 3785 L (1000 usable gal)  
 Fuel/water separator  
 110 VAC/24 VDC lighting  
 Sound attenuated (72 dBA @ 50 ft)

#### Cooling

Standard cooling provides 105° ambient at  
 prime rating.

#### Switchgear

Floorstanding switchgear with EMCPII  
     components  
 Automatic start/stop with cooldown timer  
 Battery charger, heavy duty, 20A  
 Protection: 32,59  
 Circuit breaker, electrically operated

### CATERPILLAR® 3516 ENGINE

---

V-16, Four-Stroke-Cycle Diesel, 1800 rpm  
 Bore—mm (in) ..... 170 (6.7)  
 Stroke—mm (in) ..... 190 (7.5)  
 Displacement—L (cu in) ..... 69.0 (4210)  
 Aspiration ..... Turbocharged-Aftercooled

Connection terminals, three-phase and neutral  
 Automatic paralleling  
 Auxiliary power connections for jacket water  
     heater, battery charger, and space heaters

#### Enclosure

ISO hi cube container  
 Lockable doors prevent vandalism or unsafe  
     operating conditions  
 Separate vented battery compartment allows  
     easy access to batteries which are housed in a  
     separate, clean environment for longer life.  
 Sound attenuation satisfies customer  
     requirement for quiet rental units. Eliminates  
     noise complaints.

Stainless steel hardware and hinges provide  
     superior rust corrosion protection.  
 Vertical radiator and exhaust discharge plenum  
     contribute to sound attenuation performance.  
     Directs hot air and diffuses radiator discharge  
     and exhaust gases upward, away from  
     bystander and package. Allows for placement  
     of power module next to a building or other  
     obstruction that may restrict flow to the  
     radiator.

*NOTICE: This package must be ordered for utility  
 convertible switchgear components to be  
 compatible.*

### OPTIONAL EQUIPMENT

---

#### Container

Roof air intake louvers

#### Switchgear

Meters: kW, PF, W/WHM, synchroscope, KVAR  
 Protection: 27, 40, 810, 81U  
 CIM, CCM, remote annunciation  
 Plug & peak shave utility conversion panel

### CATERPILLAR® SR4 GENERATOR

---

Type ..... Static regulated brushless PM excited  
 Construction ..... Single bearing, close coupled  
 Three phase ..... wye connected, six lead  
 Insulation ..... Class H – two extra dips and  
     bakes on random wound units  
 Enclosure ..... Drip proof  
 Alignment ..... Pilot shaft  
 Overspeed capability ..... 130%  
 Voltage regulator ..... 3-phase sensing with  
     Volts-per-Hertz  
 Voltage regulation ..... Less than ± 1%  
 Voltage gain ..... Adjustable to compensate for  
     engine speed droop and line loss  
 Wave form ..... Less than 5% deviation  
 TIF ..... Less than 50  
 THF ..... Less than 3%

**TECHNICAL DATA**

3516 Generator Sets			XQ1750
<b>Rating Information</b>	Engine 60 Hz – 1800 rpm		3516
	Prime power rating (plus 10% overload) @ 0.8PF with fan	kW	1600
	Standby power rating @ 0.8PF with fan	kW	1750
	Voltage Aspiration		480 TA
<b>Physical Factors – Package with Undercarriage</b>	Length	cm <b>in</b>	1219 <b>480</b>
	Width	cm <b>in</b>	234 <b>92</b>
	Height	cm <b>in</b>	411 <b>162</b>
	Shipping weight	kg	28 700
		<b>lb</b>	<b>63 500</b>
<b>Lubrication &amp; Cooling Systems</b>	Engine lubricating oil capacity	L <b>qts</b>	470 <b>497</b>
	Engine coolant capacity w/radiator (with 50% glycol)	L	440
		<b>gal</b>	<b>116</b>
<b>Engine Performance Data @ Rated Conditions</b>	Fuel tank capacity	L <b>gal</b>	4732 <b>1250</b>
	Fuel consumption prime (100% load) w/fan per ISO 3046/1 +55, -0% tolerance	L/Hr	504.7
		<b>gph</b>	<b>133.4</b>
	Fuel consumption (75% load) w/fan	L/Hr	378.1
		<b>gph</b>	<b>99.9</b>
	Fuel consumption (75% load) w/fan	L/Hr	264.6
		<b>gph</b>	<b>69.9</b>
	Deration: Altitude – 3.0% per 305 m (1000 ft) above	m <b>ft</b>	1375 <b>4510</b>
		Temperature – 1.9% per 5.5° C (10° F) above	° C ° F
	at sea level or degree above standard ambient at altitude above 760 m (2500 ft).		
	Sound level – prime +10% @ 16 m (50 ft)	dbA	72

**DIMENSIONS**



40 ft	L		H		W	
	cm	in	cm	in	cm	in
	1219	480	290	114	234	92

- NOTE: The container meets or exceeds the following standards and regulations.
- ISO/TC 104 Requirements for Cargo Containers
  - ANSI/MH5.1 Basic Requirements for Cargo Containers
  - ANSI/MH5.1.1 Requirements for Closed Van Containers
  - UIC CODE 592-1

The module must have support under the center when set on the ground.

3516 requires tri-axle chassis.

Maximum weight allowed on Interstate highways is 34 000 lb (rear axles). 3516 typically weighs 33 000 lb as shipped. The complete unit weighs 55 000 lb gross with chassis. Empty chassis weighs 6000 lb. These weights do not include tractor.

## UTILITY CONVERTIBLE SWITCHGEAR

Floorstanding switchgear includes the following functions and features:

### Electronic Modular Control Panel (EMCP II) Components

#### Generator Set Control (GSC)

##### Monitoring

Sequentially rotating, backlit LCD display of engine hours, engine rpm, DC battery voltage, oil pressure and water temperature. Includes push-button to hold display on any single parameter.

##### Protection

##### Shutdowns:

Overspeed, overcrank, high water temperature, low oil pressure, and emergency stop. With LED indicator for each condition.

##### Alarms:

Low coolant level

##### AC Metering

Three-phase volts (L-L), amperes and frequency with phase select pushbutton, on backlit LCD. Metering accuracy is 0.5%.

##### Control

Automatic starting with field adjustable cycle crank, failure to start (overcrank), and cooldown timer.

##### Programming and Diagnostics

Includes field programmable set-points for engine control and monitoring variables and self diagnosis of EMCP II system component and wiring failures.

#### Alarm Module

Flashing LED warnings for: low coolant temperature, high coolant temperature (pre-alarm), low oil pressure (pre-alarm), engine control switch not in automatic, and low DC voltage. Includes alarm horn and acknowledge pushbutton.

#### Engine Control Switch

Snap action rotary switch, four position – off/reset, automatic, stop/cooldown. Off/reset for engine shutdown and resetting faults, automatic remote starting by customer contact closure, manual for local starting and manual paralleling, stop/cooldown for manual operation cooldown.

#### Alarm Acknowledge/Lamp Test Switch

Three-position, spring return to center switch for alarm acknowledge and lamp test of all discrete indicating lamps. Lamp test shall also sound the alarm horn.

#### Annunciation Circuits

Upon receipt of an alarm or shutdown condition, the horn shall sound and an LED shall flash. Upon acknowledgement from alarm acknowledge/lamp test switch, the horn shall be silenced and the lamp steadied. LED shall be extinguished when ECS is placed in the off/reset position if the alarm condition has been corrected. Circuits are recurring such that the LED shall flash and the horn sound, should another fault occur even prior to correction of the initial fault.

#### Emergency Stop Pushbutton

Mushroom head, twist to reset, causes engine shutdown and tripping of the generator circuit breaker. Prevents engine starting when depressed.

#### Circuit Breaker Control Switch

Heavy duty, three-position spring return to center with momentary trip and close position and slip contacts (nac) for automatic closing. Pull to lock feature in trip position. Includes circuit breaker position indicating lamps.

#### Dead Bus Closing Circuit

For standby operation only, permits automatic or manual closing of the generator set circuit breaker to a dead load bus.

#### Failed to Auto-Parallel

Field adjustable time delay circuit to cause engine shutdown if the generator circuit breaker fails to close after initiation of automatic operation.

#### Generator Main Circuit Breaker

3000A fix mounted, three-pole, electrically operated, insulated case circuit breaker with solid state trip unit for overload (time overcurrent) and fault (instantaneous) overcurrent protection, with door mounted overcurrent indicating lamp and latching circuit. Includes DC shunt trip coil activated on any monitored engine or electrical fault. 100KA interrupting capacity at 480VAC.

#### Electronic Load Sharing Governor and Associated Circuitry

Electronic load sharing governor. Includes speed adjust potentiometer, idle/rated switch and isochronous/droop switch.

#### Speed Matching Automatic Synchronizing Circuitry

Automatically synchronizes and parallels the generator with a live bus.

#### Manual Paralleling

Synchronizing lights (2) and switch for manual paralleling.

#### Voltage Regulation

Standard Caterpillar generator-mounted voltage regulator with voltage adjust rheostat mounted in the floorstanding switchgear.

#### Current Transformers

CTs rated 3000:5 with secondaries wired to shorting terminal strips.

#### Potential Transformers

480VAC primary, 120VAC secondary with primary and secondary fuse protection, two connected to the generator side of the generator circuit breaker, two connected to the load side of the circuit breaker.

#### AC Metering

AC voltage, current, and frequency shall be displayed on generator set control as an integral part of its display.

#### Generator Protection

Protective relays include field adjustable pick-up and time delay. Operation of industrial grade relays is indicated by trip target and sounding of the alarm horn.

#### Reverse Power Relay

ANSI device 32, single-phase sensing. Activation of relay causes tripping of the generator circuit breaker and immediate engine shutdown. Relay is panel mounted industrial type.

## UTILITY CONVERTIBLE SWITCHGEAR (Continued)

### Over Voltage Relay

ANSI device 59, single-phase sensing. Activation of relay causes tripping of the generator circuit breaker and immediate engine shutdown. Relay is panel mounted industrial type.

### Accessory Power

Three 120 VAC shore power connections for jacket water heaters, generator space heater, and battery

charger. Includes fault protection and relays to de-energize jacket water heaters and generator space heater when the engine is running.

### Battery Charger

24VDC/20A battery charger with float/equalize modes and charging ammeter.

## PLUG & PEAK SHAVE UTILITY CONVERSION PANELS (Sold Separately)

The plug & peak shave utility conversion panels may be used with specially configured utility convertible switchgear. Two plug & peak shave panels are provided, both panels are attached to the side of the switchgear. All electrical connections between the switchgear and the two remote panels are accomplished using "quick connect" type connectors.

The addition of the conversion panels will allow automatic or manual paralleling with a utility power source as a load management system with provisions for standby operation feeding an isolated load network.

Load management operation involves a microprocessor-based automatic dual dynamic loading control with soft loading, base load, and soft unloading. For standby operation the generator operates as an isochronous machine isolated from the utility supply. The controls allow for automatic operation, initiated locally or remotely by the customer's SCADA system. Dead bus closing is allowed for standby operation.

### Base Load Operation

Upon receipt of base load start signal (provided locally or remotely by customer) generator shall automatically start, obtain rated speed and voltage, synchronize to the bus, and close the generator breaker. Once the generator is connected to the utility, the generator output is gradually increased up to the base load setting of the load control. Generator output will remain at the base load level until the generator is signaled to shut down. When signaled to shut down, the load control will gradually decrease generator output and trip open the generator circuit breaker. When the unload setting of the load control is reached, the engine is then placed in cooldown mode. Field adjustable parameters include load time, unload time, and base load level (generator steady state output.)

### Standby Operation

Upon receipt of standby start signal (provided locally or remotely by customer) generator shall automatically start, obtain rated speed and voltage, and close the circuit breaker onto dead bus. Customer shall ensure that load is less than the generator set is capable of block loading, and ensure that load bus is disconnected from utility source. When signaled to shut down, the generator breaker shall trip and the engine is placed in the cooldown mode. At that time utility may be reconnected to load bus.

### Load Sharing

During standby operation the engine governor set

shall be set for isochronous load sharing with other parallel units.

The panels shall include the following functions and features:

### Local Start/Stop Switch

Three-position, spring return to center for local start and stop control.

### Utility Metering

The following shall be simultaneously displayed on the Operator Interface Unit (OIU).

- Single-phase utility voltage
- Utility frequency
- Generator kW
- Generator PF

### Operator Interface Unit (OIU)

Used to interact with system microprocessor to control loading characteristics; also provides metering functions.

### Power Factor Control Circuitry

Power factor control circuitry for maintaining constant generator power factor while paralleled with the utility. Includes provisions for manual power factor adjustment.

### Manual Loading Control Circuitry

Redundant back-up to microprocessor base loading controls. Operative when microprocessor is disabled by an operator or has malfunctioned. Provides manual adjustment using potentiometer, of generator power output while operating in parallel with the utility.

### Protection

Protective relays include adjustable pick-up and time delay. Operation is indicated by trip target and sounding of the alarm horn.

### Phase Sequence/Under Voltage Relay

ANSI device 47/27, three-phase sensing. Protects systems from utility loss/fault while operating in parallel. Activation of relay causes tripping of the generator circuit breaker and places engine in cooldown mode of operation. Relay is disabled when operating isolated from the utility. Relay is solid state draw-out type.

### Over/Under Frequency Relay

ANSI device 81O/U. Settings for overfrequency and underfrequency with time delays, adjustable in cycles. Protects systems from utility loss/fault while operating in parallel. Activation of relay causes tripping of the generator circuit breaker and places engine in cooldown mode of operation. Relay is disabled when operating isolated from the utility. Relay is solid state draw-out type.

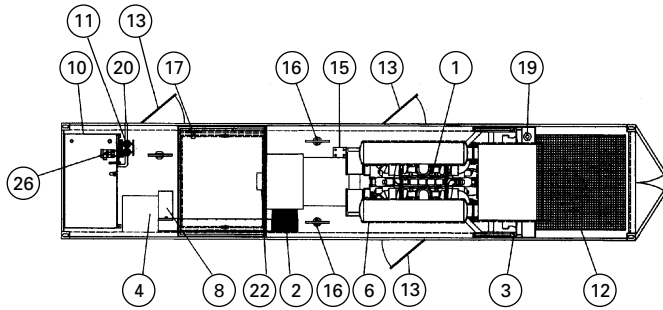

Floor Plan

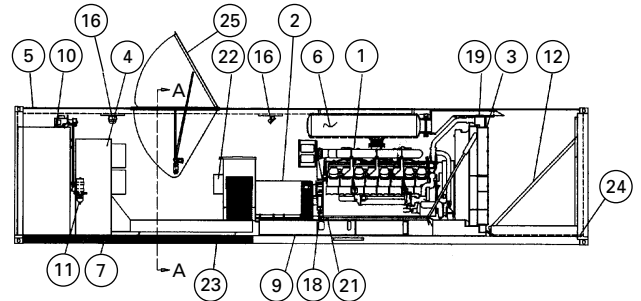

3516 4-Turbo Power Module  
Interior Layout Roadside View

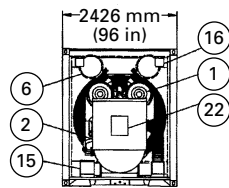

Section A-A

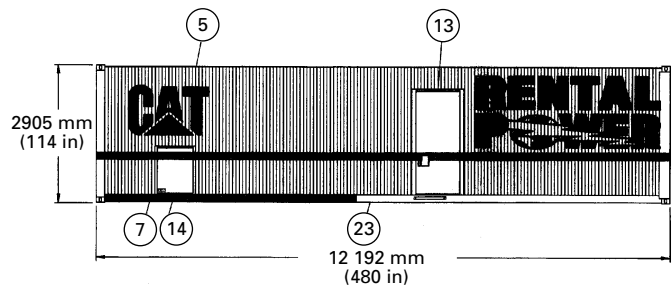

3516 4-Turbo Power Module  
Roadside View

- |                                  |                                       |                         |
|----------------------------------|---------------------------------------|-------------------------|
| ① 3516 4-Turbo Engine            | ⑨ Vibration Isolator Pads             | ⑱ Jacket Water Heater   |
| ② 824 Frame SR4B 480V Generator  | ⑩ 1250 Gallon Fuel Tank – U.L. Listed | ⑲ Radiator Fill         |
| ③ 46 CVL Radiator                | ⑪ Fuel/Water Separators               | ⑳ 1.5 inch Fuel Drain   |
| ④ Floorstanding Switchgear       | ⑫ Vertical Discharge Chute            | ㉑ 0.75 inch Oil Drain   |
| ⑤ 40 ft. ISO Dry Cargo Container | ⑬ Entrance Door                       | ㉒ Literature Box        |
| ⑥ 30 dBA Muffler                 | ⑭ Load Cable Access Door              | ㉓ Insulated Floor       |
| ⑦ Channel Reinforcement          | ⑮ 24V Batteries and Rack              | ㉔ 1 inch Radiator Drain |
| ⑧ Utility Conversion Panels      | ⑯ 24 Volt Light                       | ㉕ Roof Door             |
|                                  | ⑰ Light Switch                        | ㉖ Fuel Transfer System  |

NOTE: The container meets or exceeds the following standards and regulations.

- ISO/TC 104 requirements for cargo containers
- ANSI/MH5.1 basic requirements for cargo containers
- ANSI/MH5.1.1 requirements for closed van containers
- UIC code 592-1 International Union of Railway

The module must have support under the center when set on the ground.

Shipping weight: 63 060 lbs.